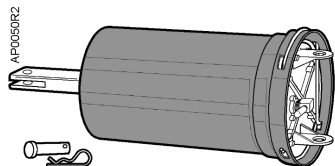
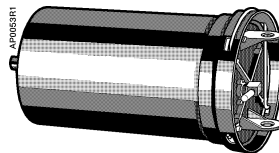


Powers™ Controls

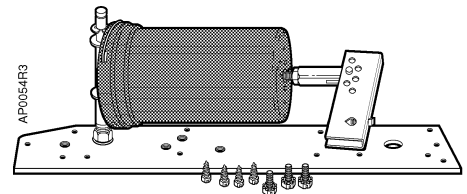
No. 4 Pneumatic Damper Actuator




**Actuator Assembly
331-2929 Typical**



**Actuator Assembly
331-2904 Typical**



**Actuator Assembly
331-3000 Typical**

Description	The Powers Controls No. 4 Pneumatic Damper Actuator is a totally enclosed pneumatic piston type actuator designed to operate dampers for ventilating systems, mixing box control, and other applications requiring a large effective diaphragm area and long stroke.
Features	<ul style="list-style-type: none"> • All metal body construction • Replaceable ozone resistant rolling diaphragm • Pivot mounting for extended shaft or frame mounting • Fixed bracket mounting • Direct front mounting • Positioning relay (optional) • Forward travel stops (optional) • Adjustable hesitation point (hesitation actuator only)
Product Numbers	See Table 1.
Application	<p>The No. 4 Pneumatic Damper Actuator is recommended for control of outdoor, return air, exhaust, face and bypass, fan discharge, and static pressure control dampers, as well as specialized dampers and air valves found in terminal units such as unit ventilators and mixing boxes.</p> <div style="display: flex; align-items: flex-start;"> <div style="margin-right: 10px;">  </div> <div> <p>Certain actuators in Table 1 are UL Recognized Components for fire/smoke applications under category EMKU2. This category covers pneumatic damper actuators intended to be employed on fire dampers and leakage rated dampers.</p> </div> </div> <p>The No. 4 Pneumatic Damper Actuator hesitation model is frequently used to operate the outdoor air damper on unit ventilators. The hesitation feature enables the outdoor air damper to be synchronized with the unit valve to maintain a predetermined outdoor air requirement when the controlled zone is at the desired temperature.</p>

Warning/Caution Notations



WARNING		Personal injury/loss of life may occur if the user does not follow a procedure as specified.
CAUTION		Equipment damage, or loss of data may occur if the user does not follow a procedure as specified.

Table 1. Product Numbers for No. 4 Pneumatic Damper Actuator.

Description	Mounting Style	Product Numbers				
		Nominal Spring Range				
		3-7 psi (21-48 kPa)	3-13 psi (21-90 kPa)	5-10 psi (35-69 kPa)	8-13 psi (55-90 kPa)	2-3, 8-13 psi (14-21, 55-90 kPa) Hesitation Model
Actuator, mounting screws (non-pivot)	Front	331-2910	—	331-2917	331-2963	—
Actuator, bracket (non-pivot) 3-inch stroke for unit ventilator	Fixed	331-2911	—	331-2934	331-2966	331-2927
Actuator, bracket (non-pivot) 2-3/8 inch stroke for unit ventilator	Fixed	—	—	—	—	331-2974
Actuator, mounting plate, ball joint connector	Fixed	331-3015	331-3018	331-3016	331-3017	331-3019
Actuator, mounting plate, ball joint connector with positioning relay	Fixed	—	—	—	332-3017	—
Actuator, integral pivot	Pivot	331-2904 ¹	331-2905 ¹	331-2906 ¹	331-2961 ¹	331-2909 ¹
Actuator, integral pivot, clevis and clevis pin for use with frame mounting accessory	Pivot	331-2929	331-2930	331-2931	331-2968	—
Actuator, integral pivot with pivot post ²	Universal Kit	331-3000	331-3001	331-3002	331-2973 ¹	331-3004
Actuator, integral pivot with pivot post and positioning relay ²	Universal Kit with Positioning Relay	—	—	—	332-2973	—

¹ UL Recognized Components for Fire/Smoke Applications.

² Mounted on plate for extended shaft with clevis and crank for 3/8-inch (10-mm), 7/16-inch (11-mm), or 1/2-inch (13-mm) diameter shaft. Parts for frame mounting (blade drive) included with kit.

NOTE: When the actuator is ordered with universal mounting, the mounting plate, pivot post and hardware, clevis, damper crank, and all screws/nuts are included. Order other frame mounting accessories as required, if not supplied by damper manufacturer.

Specifications	Effective diaphragm area	11 inches ² (71 cm ²)
	Stroke	4 inches (102 mm)
	Stroke (Hesitation model)	3 inches (76 mm)
	Stem	Stainless steel
	Housing	Steel with cathodic epoxy electrocoat
	Diaphragm	Ozone-resistant rubber
	Maximum air pressure	30 psig (210 kPa)
	Nominal spring ranges	3 to 7 psi (21 to 50 kPa) 3 to 13 psi (21 to 90 kPa) 5 to 10 psi (35 to 70 kPa) 8 to 13 psi (55 to 90 kPa)
	Nominal spring range (Hesitation model)	2 to 3; 8 to 13 psi (14 to 21; 55 to 90 kPa)
	Ambient temperature range-operating	35°F to 140°F (2°C to 60°C) -20°F to 140°F (-29°C to 60°C)
	Air connection elbow barb fitting for 1/4-inch O.D. plastic tubing	Installed in 1/8-inch NPT opening
	Type of mounting	Front, bracket, pivot
	Thrust and torque rating	See Table 2
	Dimensions	See Figure 14
Agency Approvals	Complies with UL555 and UL555S	

Table 2. Thrust and Torque Rating.

Nominal Spring Range	Maximum Thrust lb. (N)				Torque Rating * lb-in (Nm)			
	Full Stroke Forward			Spring Return (No stroke) 0 psig (0 kPa)	Gradual Operation	2-position Operation or with Positioner		
	15 psi (103 kPa)	18 psi (124 kPa)	25 psi (172 kPa)			15 psi (103 kPa)	18 psi (124 kPa)	25 psi (172 kPa)
3-7 psi (21-50 kPa)	88 (391)	121 (538)	198 (881)	33 (147)	30 (3.4)	46 (5.2)	46 (5.2)	46 (5.2)
3-13 psi (21-90 kPa)	22 (98)	55 (245)	132 (587)	33 (147)	30 (3.4)	30 (3.4)	46 (5.2)	46 (5.2)
5-10 psi (35-70 kPa)	55 (245)	88 (391)	165 (734)	55 (245)	30 (3.4)	77 (8.7)	77 (8.7)	77 (8.7)
8-13 psi (55- 90 kPa)	22 (98)	55 (245)	132 (587)	88 (391)	30 (3.4)	30 (3.4)	77 (8.7)	124 (14)
2-3, 8-13 psi (14-21, 55-90 kPa) Hesitation model	22 (98)	55 (245)	132 (587)	22 (98)	23 (2.6)	—	—	—

* With maximum hysteresis of 2.5 psi (17.2 kPa) @ 90° rotation.

Accessories

Linkage kits:	
Crank and link (Figure 9)	331-958
Rod, ball joint, and crank	331-947
Pivot post, ball joint, and crank	331-954
Cranks - damper shaft:	
5/8-inch (16 mm) diameter	333-182
3/4-inch (19 mm) diameter	333-183
1-inch (25 mm) diameter	333-181
Adjustable radius, 3/4 to 2-7/8 inch (20 to 73 mm) for 1/2 inch (13 mm) diameter damper shaft	331-795
Selectable radius (45°, 60°, or 90° rotation) for 3/8 to 1/2 inch (10 to 13 mm) diameter damper shaft	331-941
Clevis:	
Forged	331-653
Steel plated	333-207
Damper shaft extension kits:	
1/2-inch (13 mm) × 2-1/4 inch (54 mm) long (See <i>TB 128</i>)	331-631
1/2-inch (13 mm) × 9-inch (229 mm) long	333-184
Damper shaft extension kit adapter, 3/8-inch (9.5 mm)	331-632
Actuator shaft adapter, uses 1/2-inch NPT Pipe	333-030
Actuator shaft extensions:	
10-1/8-inches (257 mm) long	331-434A
Ball joint type, 12 inches (305 mm) long	331-674
Damper blade rocker arm	333-034
Damper push rods, 5/16 inch (8 mm) diameter:	
12 inches (30 cm) long	338-041
15 inches (38 cm) long	338-042
18 inches (46 cm) long	338-043
24 inches (61 cm) long	338-044
36 inches (91 cm) long	338-045
48 inches (122 cm) long	338-046
Spring clamp (secures 1/4-inch O.D. poly tubing to barb-fitting at higher control pressures or elevated temperatures)	531-833
Forward stroke stop kit	
Adjustable 2-3/8 to 4 inches (60 to 102 mm)	331-939
Positioning relay	147-2000
Positioning relay mounting kit	147-314
Universal mounting plate	331-623
Frame mounting lug	331-569
Offset mounting bracket	333-176

Service Kit

Diaphragm (Package of 5)

333-071

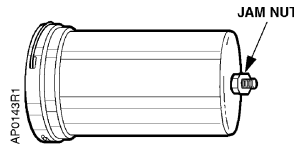


Figure 1. Actuator Jam Nut Location.



WARNING:

Do not remove the jam nut (Figure 1). Spring is under heavy load. Repair by trained personnel only.

Actuator Selection for Unit Ventilator

For specific unit ventilators, see Application Bulletins found in *Section 36 of the Powers™ Controls Installed Applications Manual (144-004)*.

Actuator Sizing

The quantity of actuators required depends on several torque factors. To determine the quantity of actuators required for the installation:

1. Obtain damper torque ratings (ft-lb/ft²) from the damper manufacturer.
2. Determine the area of the damper.
3. Calculate the total torque required to move the damper:

$$\text{Total Torque} = \text{Torque Rating} \times \text{Damper Area}$$

4. Calculate the total quantity of actuators required:

$$\text{Number of Actuators} = \frac{\text{Total Damper Torque Required}}{\text{SF}^1 \times \text{Actuator Torque (Table 2)}}$$

¹ Safety Factor: When calculating the number of actuators required, a safety factor should be included for unaccountable variables such as slight misalignments, aging of the damper, etc. A suggested safety factor is 0.80 (or 80% of the rated torque).

See *AB-300 Damper Actuator Sizing and Selection Application Bulletin in the HVAC Systems/Controls Reference Data (125-1853)* for additional sizing information. See *TB-181 Powers™ Controls Maximum Thrust Ratings of Pneumatic Damper Actuators Technical Bulletin (155-219P25)* for additional torque requirements.

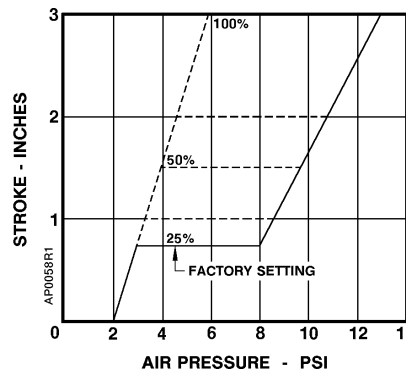


Figure 2. Hesitation Actuator Adjustment.

Operation

Standard Actuator (Figure 3)

The air tubing from a controlling instrument connects to the actuator's upper housing. With no control pressure to the actuator, the compression spring forces the diaphragm and actuator shaft toward the upper housing, but is limited by the jam nut on the actuator shaft. As the control pressure on the diaphragm increases, the spring compression is overcome and the actuator shaft gradually moves outward. Conversely, as control pressure decreases, the spring returns the shaft to the position at which the air pressure on the diaphragm balances the spring tension. For each value of control pressure there is a corresponding position of the shaft.

Hesitation Actuator (Figure 4)

The branch or return pressure from the controlling instrument connects to the upper housing of the actuator. With no branch pressure to the motor, the main spring forces the actuator shaft toward the upper housing, but is limited by the jam nut on the actuator shaft. As the branch pressure on the diaphragm increases from 0 to 2 psi (0 to 14 kPa), the compressive force in the main spring prevents the actuator shaft from moving. As the branch pressure increases from 2 to 3 psi (14 to 21 kPa), the force in the main spring is overcome and the actuator shaft moves to its hesitation point. At the hesitation point, the main spring seat is in contact with the retard spring seat. The compressive force in the retard spring prevents further actuator shaft travel between 3 and 8 psi (21 and 55 kPa). Above 8 psi (55 kPa), the resisting force in the retard spring is overcome and the actuator shaft moves to its maximum stroke between 8 and 13 psi (55 and 90 kPa).

Table 3. Construction Components (Figures 3 and 4).

Item	Part No.	Material	Description	Item	Part No.	Material	Description
1	333-099	Aluminum	Upper housing with pivot ears	7	331-915	Music wire	Retainer clip
2	333-071	Neoprene	Diaphragm (Package of 5)	8	—	Stl. tubing	Spring guide
3	—	Steel	Lower housing	9	—	Music wire	Hesitation spring
4	—	Oil-tempered steel	Spring	10	—	Steel	Cycle adjusting rod
5	—	Zytel	Bearing plate	11	041-100	Brass	10-32 Hex nut
6	—	—	Piston cup/stem				

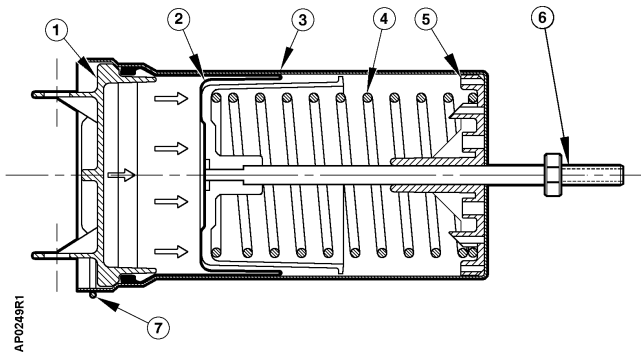


Figure 3. Standard Actuator.

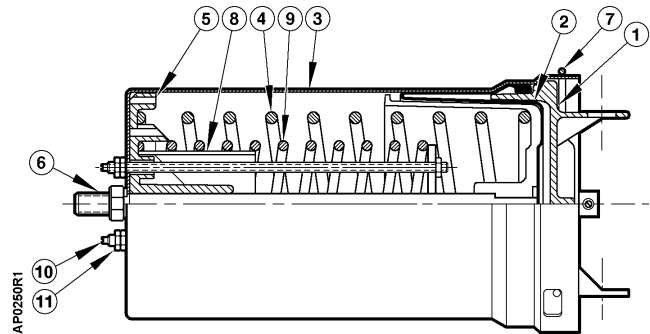


Figure 4. Hesitation Actuator.

Hesitation Actuator Adjustment

Example:

To obtain an initial hesitation point after one inch (25 mm) of shaft travel.

1. Add air pressure to the actuator until shaft travel is one inch (25 mm).
2. Turn locknuts on cycle adjustment rods until they contact lower housing, then lock together (Figure 4, Items 10 and 11). For initial hesitation point settings other than one inch (25 mm), follow this same procedure.



CAUTION:

Make certain cycle adjustment nuts are even to ensure smooth operation.

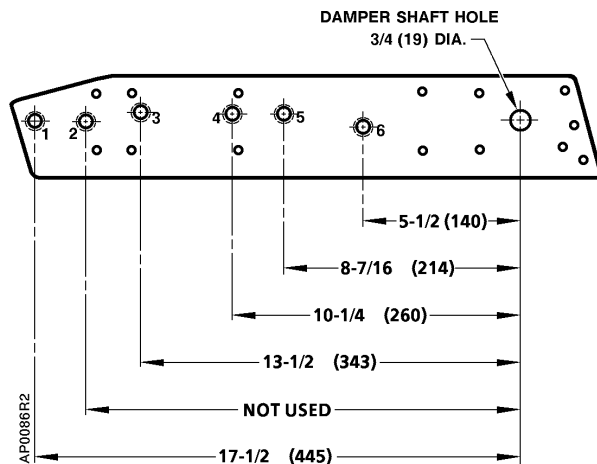
Extended Shaft Mounting - Pivot Actuator

1. Order one of the following for extended shaft mounting. These assemblies are designed for 90° damper rotation.

Actuator: 331-3000, 331-3001, 331-3002, 331-2973, or 331-3004

NOTE: Clevis mounts in Crank Radius Hole No. 1 for 90° damper rotation.

2. Slip the 3/4-inch (19 mm) diameter hole in the mounting plate over the damper shaft (Figure 5).



**Figure 5. Actuator Mounting Plate 331-623.
 Dimensions in Inches (Millimeters).**

Table 4. Mounting Plate Hole Identification.

Hole	Used For
1	No. 6 Actuator extended shaft mounting
2	Not used
3	No. 4 Actuator extended shaft
	No. 6 Actuator frame mounting N.C.
4	No. 6 Actuator frame mounting N.O.
5	No. 4 Actuator frame mounting N.C.
6	No. 4 Actuator frame mounting N.O.

Extended Shaft Mounting - Pivot Actuator, Continued

- Slip the crank over the 3/8 through 1/2-inch (10 through 13-mm) diameter damper shaft (Figure 6).

With the actuator assembly to the left of the damper shaft, an increase in actuator pressure rotates the damper blade clockwise (CW) when the crank is above the damper shaft (Figure 6), or counterclockwise (CCW) when the crank is below the damper shaft.

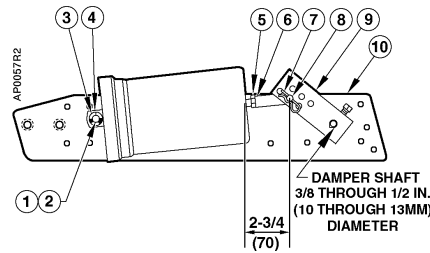


Figure 6. Actuator 331-3000 (Typical).

With the actuator assembly to the right of the damper shaft, an increase in actuator pressure rotates the damper blade CCW when the crank is above the damper shaft, or CW when the crank is below the damper shaft.

- Position the mounting plate and attach it to the duct with four screws.

Table 5. Actuator Accessories Shown in Figure 6.

Item	Part No.	Description	Qty.	Material
1	331-565	Pivot shaft	1	Steel
2	047-061J	E-ring	2	Steel
3	146-020K	Lock washer	1	Steel
4	041-162J	Nut	1	Steel
5	041-142	Nut	1	Steel
6	333-207	Clevis	1	Zinc plated steel
7	331-807	Hitch pin	1	Zinc plated steel
8	331-293	Clevis pin	1	Zinc plated steel
9	331-923	Crank assembly	1	Galvanized steel
10	331-623	Actuator mounting plate	1	Steel
—	034-283	Mounting screws	4	Steel
F	333-034	Rocker	—	Zinc plated steel
F	331-801	Clevis	1	Steel-reinforced plastic
F	034-123K	Mounting screws	3	Steel
F	041-230J	Nut	2	Steel
F	030-510J	Screws	2	Steel

"F" Parts for Frame Mounting.

Extended Shaft Mounting - Fixed Actuator

1. Order one of the following damper actuators, the clevis, and linkage kit (Figure 8):
 Actuator with mounting bracket: 331-2911, 331-2966, 331-2927, or 331-2974
 Clevis: 331-801
 Linkage Kit: 331-958
2. Determine the application, select appropriate "X" and "Y" dimensions from Table 7. Select a rigid section of the duct, if possible, and then draw these lines on the duct.

NOTE: If the "X" dimension is 8-1/2 inches (216 mm), place the rear of the actuator against the damper shaft and draw a line along the front of the bracket for the "X" dimension. Measure the "Y" dimension.

3. If the actuator assembly mounts to the *right* of the damper shaft (Figure 8):
 - Draw the "Y" dimension line above the damper shaft if the damper blade is to rotate CCW as actuator pressure increases.
 - Draw the "Y" line below the damper shaft if the damper blade is to rotate CW as actuator pressure increases.

If the actuator assembly mounts to the *left* of the damper shaft:

- Draw the "Y" dimension line above the shaft if the damper blade is to rotate CW as actuator pressure increases.
- Draw the "Y" line below the damper shaft if the damper blade is to rotate CCW as actuator pressure increases.

CAUTION:



It is important to use the "X" and "Y" dimensions in Table 7 to position the actuator. They were selected to ensure that the crank is approximately perpendicular to the actuator shaft at half its stroke. This will prevent the linkage from scissoring or locking up (see Figure 7.)

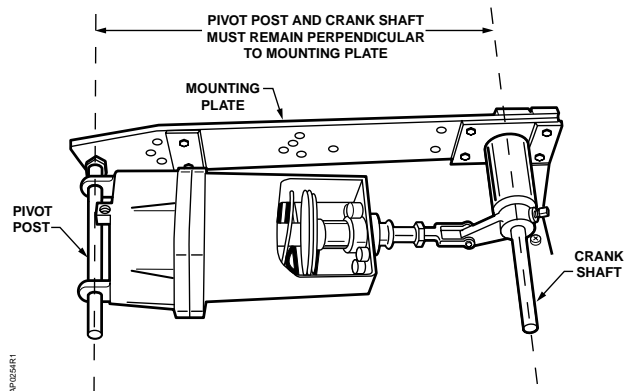
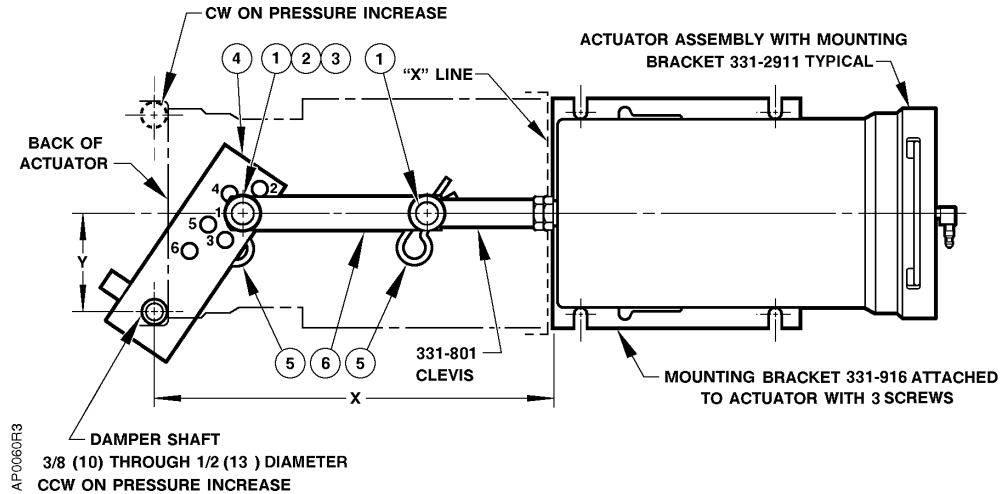


Figure 7. Perpendicular Mounting.

**Extended Shaft
 Mounting - Fixed
 Actuator,
 Continued**

4. Place the front of the actuator on the "X" dimension line so the actuator shaft faces the damper shaft. Place the centerline of the actuator over the "Y" dimension line (Figure 8).
5. Thread Clevis 331-801 onto the actuator shaft and tighten it against the lock nut. Assemble Linkage Kit 331-958 (Table 6, Items 1 through 6) to the actuator assembly per Figure 8. The linkage is assembled so the damper shaft will rotate CCW as actuator pressure increases. This is a typical normally closed damper installation.



**Figure 8. Fixed Mounted Actuator Assembly.
 Dimensions in Inches (Millimeters).**

**Table 6. Linkage Kit 331-958 Parts
 (Figure 8).**

Item	Part No.	Description	Qty.	Material
1	331-918	Clevis pin	2	Zinc plated steel
2	331-930	Spring washer	1	—
3	331-929	Washer	1	Nylon
4	331-941	Crank assembly	1	—
5	331-807	Hitch pin	2	Zinc plated steel
6	331-922	4-inch link	1	Steel

**Table 7. Linkage Kit 331-958 Crank Connections
 (Figure 8).**

Crank Hole Number	Dimensions Inches (Millimeters)		Application
	X	Y	
1	8-1/2 (216)	2 (51)	4-inch (102) stroke - 90° rotation
2	8-1/2 (216)	3 (76)	4-inch (102) stroke - 70° rotation
3	8 (203)	1-1/2 (38)	3-inch (76) stroke - 90° rotation
4	8 (203)	2-1/2 (64)	3-inch (76) stroke - 60° rotation

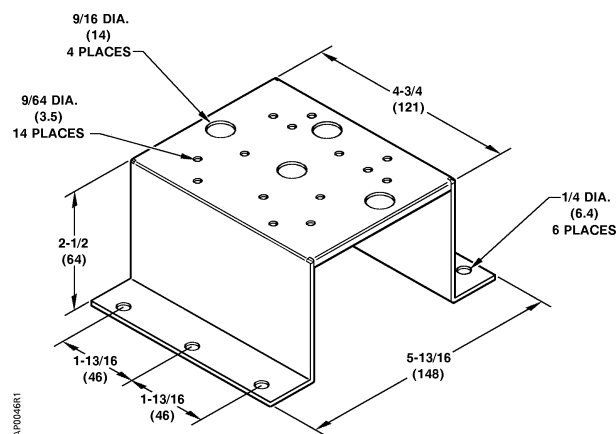
Frame Mounting

1. Order one each of the following:
Actuator assembly: 331-3000, 331-3001, 331-3002, 331-2973, or 331-3004
Mounting Lug: 331-569
2. Weld the mounting lug to the damper frame (Figure 10) so that it is parallel and 5/16-inch (8 mm) from the inside edge of the damper frame and perpendicular to it. Weld the mounting lug along both sides. The mounting lug should be as close as possible to the corner of the damper frame to minimize deflection. The damper manufacturer should weld the lug.
3. If the damper frame is aluminum, light gauge sheet metal, or an unusual shape, bolt a 3/16-inch (5-mm) thick, flat piece of steel to the frame. Then, weld the mounting lug to the piece of steel.
4. Attach the rocker to the blade in the proper position for a normally open or normally closed damper (Figure 10).
5. Attach the mounting plate to the mounting lug.
 - Normally open damper: Attach the plate to the lug (Figure 12). Place the pivot post in Hole 6.
 - Normally closed damper: Attach the plate to the lug (Figure 13). Place the pivot post in Hole 5.
6. Fasten the clevis to the rocker. Discard the crank and other parts not used.
7. The actuator mounting plate has a tendency to pivot at the point where the lug is welded to the damper frame when the actuator strokes. It is recommended that some means be devised in the field to prevent this from happening. A threaded rod attached to mounting plate and duct wall will normally do the job.

Offset Mounting Bracket

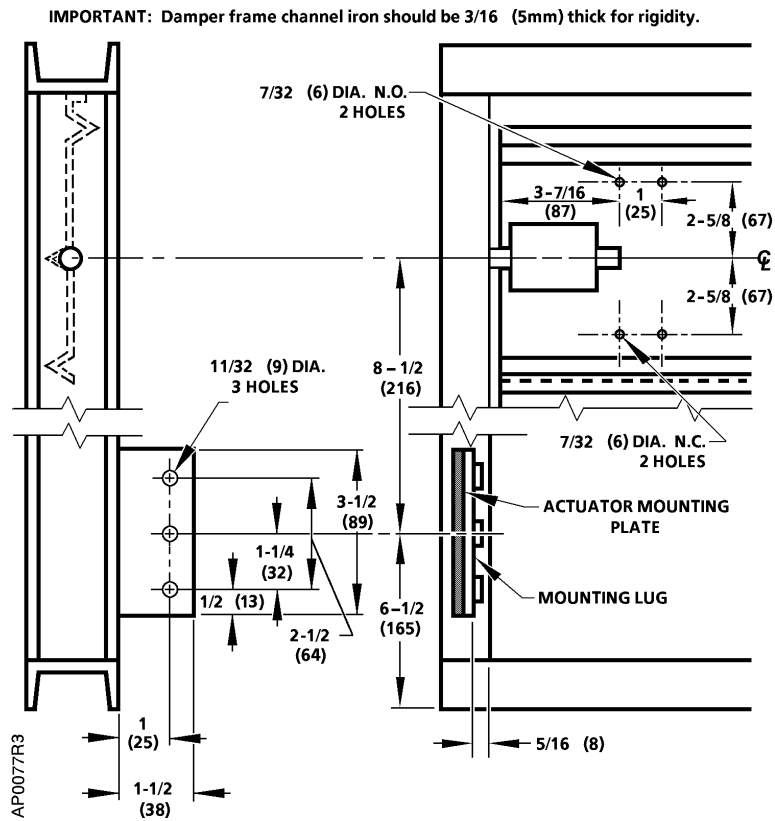
This bracket is designed to offset the Universal Mounting Plate 331-623 from ductwork and insulation.

NOTE: Depending on the application, two brackets may be required to support the actuator and universal mounting plate.



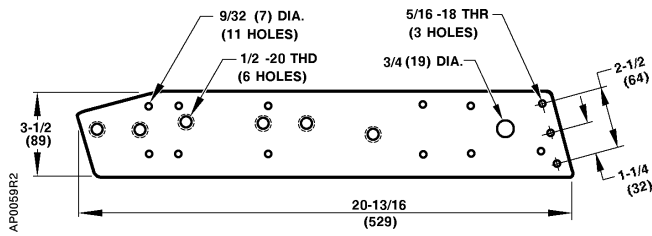
**Figure 9. Offset Mounting Bracket 333-176.
Dimensions in Inches (Millimeters).**

Dimensions



**Figure 10. Frame Mounting Dimensions.
Dimensions in Inches (Millimeters).**

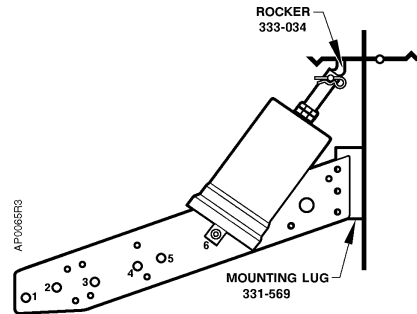
Dimensions, Continued



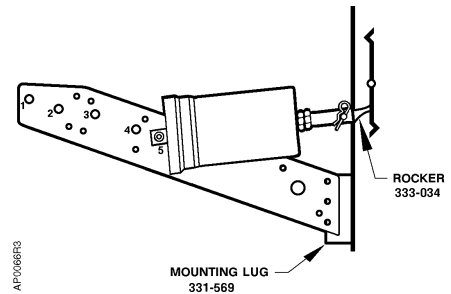
**Figure 11. Actuator Mounting Plate 331-623,
 1/4-Inch (6 mm) Thick.
 Dimensions in Inches (Millimeters).**

**Table 8. Mounting Plate Hole
 Designations (Figure 11).**

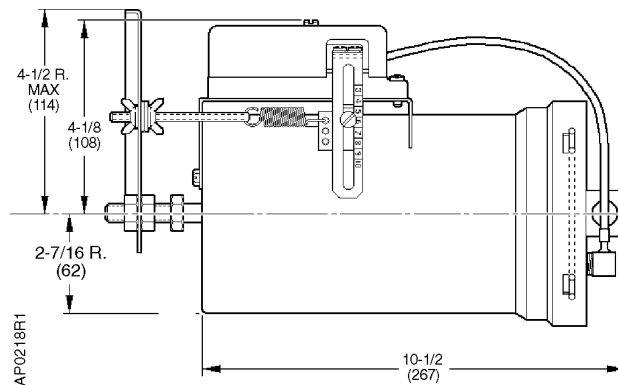
Hole	Description
1	No. 6 actuator extended shaft mounting
2	Not used
3	No. 4 actuator extended shaft No. 6 actuator frame mounting N.C.
4	No. 6 actuator frame mounting N.O.
5	No. 4 actuator frame mounting N.C.
6	No. 4 actuator frame mounting N.O.



**Figure 12. Frame Mounting
 Normally Open Damper.**

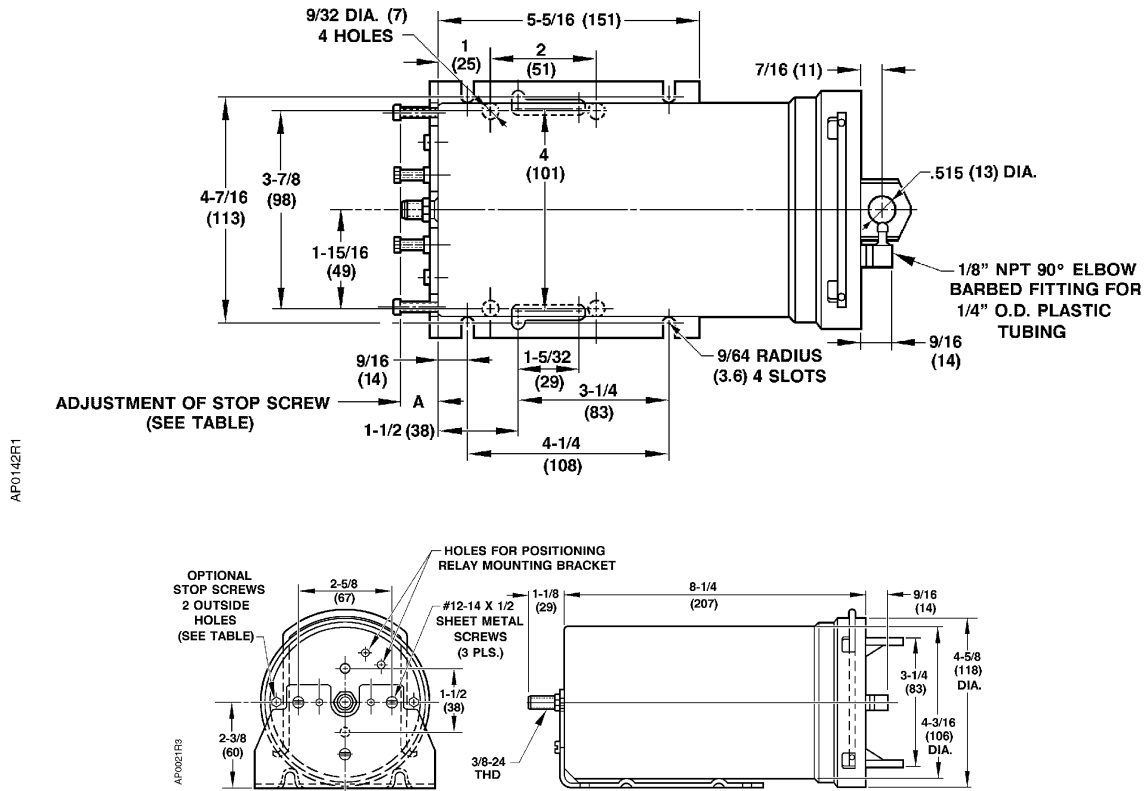


**Figure 13. Frame Mounting
 Normally Closed Damper.**



**Figure 14. Dimensions with the RL 147 Positioning Relay Mounted.
 Dimensions in Inches (Millimeters).**

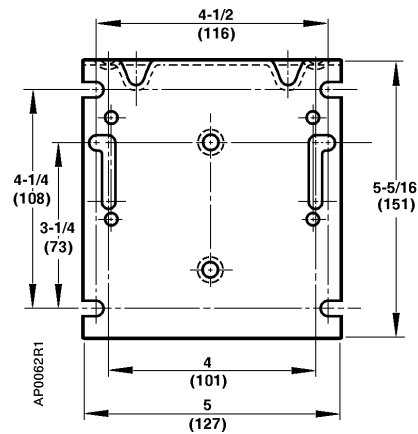
Dimensions, Continued



**Figure 15. Bracket Mounted Actuator 331-2911 (Typical).
 Dimensions in Inches (Millimeters).**

Table 9. Stop Screw Adjustment and Stroke Length (Figure 15).

Stop Screw Adjustment Dimension "A" Inches (Millimeters)	Stroke Length Inches (Millimeters)	
	Kit 331-938	Kit 331-939
IN 0	3.0 (76)	2-3/8 (60)
0.5 (13)	3.5 (89)	2-7/8 (73)
1.0 (25)	4.0 (102)	3-3/8 (85)
1.5 (38)	4.0 (102)	3-7/8 (98)
2.0 (51)		4.0 (102)
OUT 2-1/4 (57)		4.0 (102)



**Figure 16. Mounting Bracket Dimensions.
 Dimensions in Inches (Millimeters).**

Information in this publication is based on current specifications. The company reserves the right to make changes in specifications and models as design improvements are introduced. Powers is a trademark of Siemens Building Technologies, Inc. Other product or company names mentioned herein may be the trademarks of their respective owners. © 2002 Siemens Building Technologies, Inc.