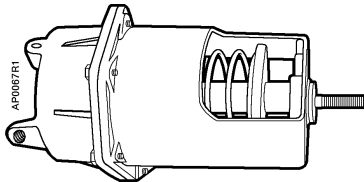
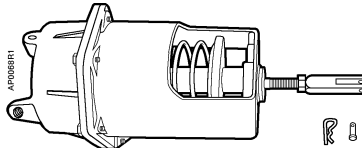


## Powers™ Controls

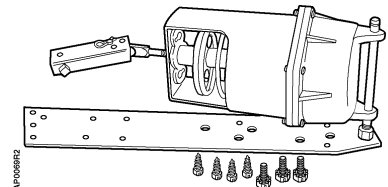
### No. 6 Pneumatic Damper Actuator



331-2793 Actuator



331-2857 Actuator  
with Clevis and Pin



331-3012 Extended Shaft and Frame  
Mounting

#### Description

The Powers Controls No. 6 Pneumatic Damper Actuator is a heavy-duty, rolling diaphragm, spring return actuator designed to drive large dampers, centrifugal refrigeration inlet vanes, and other applications requiring a large, effective diaphragm area and long stroke.

#### Features

- All metal body construction
- Replaceable ozone-resistant rolling diaphragm
- Pivot mounting for extended shaft or frame mounting
- Positioning relay (optional)
- Adjustable forward travel stops (optional)
- Three spring ranges for sequencing with other control devices

#### Product Numbers

See Table 1.

#### Application

The No. 6 Pneumatic Damper Actuator controls outdoor, return air, exhaust, face and bypass, and fan discharge dampers. It is recommended for heavy duty applications utilizing multi-section dampers where either unison or sequence operation is required.



Certain actuators in Table 1 are UL Recognized Components for fire/smoke applications under category EMKU2. This category covers pneumatic damper actuators intended to be employed on fire dampers and leakage rated dampers.

**Table 1. Product Numbers for No. 6 Pneumatic Damper Actuators.**

Description	Mounting Style	Product Numbers		
		Nominal Spring Range		
		3-8 psi (21-55 kPa)	3-13 psi (21-90 kPa)	8-13 psi (55-90 kPa)
Actuator, integral pivot	Pivot	331-2793	331-2794	331-2792 <sup>1</sup>
Actuator, integral pivot and forward travel stops (Figure 13)	Pivot	—	331-2796	331-2795
Actuator with clevis for frame mounting (Figure 6) or remove extended shaft mounting (Figure 3)	Pivot <sup>2</sup>	331-2857	331-2858	331-2856 <sup>1</sup>
Actuator with clevis and positioning relay (Figure 16)	Pivot <sup>2</sup>	—	—	332-2856
Actuator, integral pivot with pivot post <sup>3</sup>	Extended Shaft	331-3012	331-3013	331-3011 <sup>1</sup>
Actuator, integral pivot with pivot post and positioning relay <sup>3</sup> (Figure 16)	Extended Shaft with Positioning Relay	—	—	332-3011
Actuator, extended temperature range	Pivot	—	—	331-3060 <sup>1</sup>

<sup>1</sup> UL Recognized Components for Fire/Smoke Applications.

<sup>2</sup> Also order frame mounting kit accessories.

<sup>3</sup> Mounted on plate for extended shaft with clevis and crank for 3/8-inch (10-mm), 7/16-inch (11-mm), or 1/2-inch (13-mm) diameter shaft. Parts for frame mounting (blade drive) included with kit.

**NOTE:** When the actuator is ordered with universal mounting, the mounting plate, pivot post and hardware, clevis, damper crank, rocker arm, and all screws/nuts are included. Order other frame mounting accessories as required if not supplied by damper manufacturer.

Specifications		
Effective diaphragm area		17.9 inches <sup>2</sup> (115 cm <sup>2</sup> )
Stroke		4 inches (102 mm)
Housing		Aluminum
Stem		Type 416 stainless steel
Diaphragm		Ozone-resistant rubber
Spring		Steel
Bearing		Bronze oilite
Maximum air pressure		30 psig (210 kPa)
Nominal spring ranges		3 to 8 psi (21 to 55 kPa) 3 to 13 psi (21 to 90 kPa) 8 to 13 psi (55 to 90 kPa)
Ambient temperature range		-20 to 160°F (-29 to 71°C)
Air connection		1/8-inch NPT
Type of mounting		Pivot, universal (extended shaft or frame mount)
Thrust and torque rating		See Table 2
Dimensions		See Figures 13 through 16
Shipping Weight		9.0 lb. (4.08 kg)
Agency Approvals		Complies with UL555 and UL555S

<b>Accessories</b>		
	Damper shaft extension kits:	
	1/2-inch (13-mm) diameter. 2-1/4 inch (57-mm) rod (See <i>TB-128 Powers™ Controls Damper Shaft Extension Technical Bulletin</i> (155-205P25))	331-631
	1/2-inch (13-mm) diameter, 9-inch (229-mm) long hollow rod	333-184
	1/2-inch (13-mm) diameter, 9-inch (229-mm) long rod	333-042
	Damper shaft extension kit adapter - 3/8 inch (10 mm) diameter (for use with Damper Shaft Extension Kit 333-042)	331-632
	Actuator shaft extensions:	
	10-1/8 inch (257-mm) long	331-434A
	Adapter kit for 1/2-inch NPT pipe	333-030
	Cranks - damper shaft:	
	3/8-inch (10-mm) - 1/2-inch (13-mm) diameter, Selectable radius	331-941
	5/8-inch (16-mm) diameter	333-182
	3/4-inch (19-mm) diameter	333-183
	1-inch (25-mm) diameter	333-181
	Cast iron crank with set screws	333-078
	Linkage kit, 4 inch (102-mm) link and crank	331-958
	Linkage kit, 4-inch (102-mm) rod, ball joint, and crank	331-947
	Universal mounting plate	331-623
	Flange bearing (1/2 inch, 13 mm) (for 331-623 Universal Mounting Plate)	331-862
	Right angle mounting plate	333-208
	Remote mounting kit (extended shaft), Figure 3	331-618
	Positioning relay	147-2000
	Positioning relay mounting kit	147-276
	Frame mounting kits	
	One-section damper (Figure 7)	331-833*
	Two-section damper	331-834*
	Three-section damper	331-835*
	Damper blade clip kit	331-838*
	* Order frame mounting kits and damper blade clip kit from Arrow United or Pacific Air Products.	
	Frame mounting lug	331-569
	Mounting lug screws (3)	034-123K
	Offset Mounting Bracket (Figure 14)	333-176
	Travel Stop Kit (for model 3 and 4 actuators only)	333-197
	Damper Blade Rocker Arm	333-034
	Screws (2)	030 510J
	Nuts (2)	041-230K
<b>Service Kits</b>	Diaphragms	
	Standard (package of 5)	333-206
	Heavy Duty (High Temp. to 300°F [149°C])	331-077A

## Actuator Sizing

The quantity of actuators required depends on several torque factors. To determine the quantity of actuators required for the installation:

1. Obtain damper torque ratings (ft-lb/ft<sup>2</sup>) from the damper manufacturer.
2. Determine the area of the damper.
3. Calculate the total torque required to move the damper:

$$\text{Total Torque} = \text{Torque Rating} \times \text{Damper Area}$$

4. Calculate the total quantity of actuators required:

$$\text{Number of Actuators} = \frac{\text{Total Damper Torque Required}}{\text{SF}^1 \times \text{Actuator Torque (see Table 2)}}$$

- <sup>1</sup> Safety Factor: When calculating the number of actuators required, a safety factor should be included for unaccountable variables such as slight misalignments, aging of the damper, etc. A suggested safety factor is 0.80 (or 80% of the rated torque).

See *AB-300 Damper Actuator Sizing and Selection Application Bulletin in the HVAC Systems/Controls Reference Data* (125-1853) for additional sizing information. See *TB-181 Powers™ Controls Maximum Thrust Ratings of Pneumatic Damper Actuators Technical Bulletin* (155-219P25) for additional torque requirements.

**Table 2. Thrust and Torque Rating.**

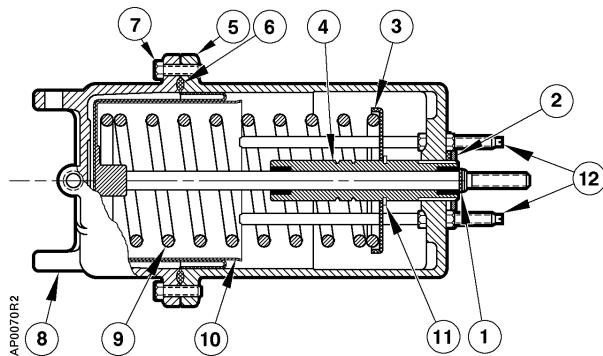
Nominal Spring Range	Maximum Thrust lb. (N)				Torque Rating* lb-in (Nm)			
	Full Stroke Forward			Spring Return (No Stroke) 0 psi (0 kPa)	Gradual Operation	2-Position Operation or Positioner		
	15psi (103 kPa)	18 psi (124 kPa)	25 psi (172 kPa)			15 psi (103 kPa)	18 psi (124 kPa)	25 psi (172 kPa)
3-8 psi (21-55 kPa)	125 (556)	179 (796)	304 (1352)	54 (240)	50 (5.6)	75 (8.5)	75 (8.5)	75 (8.5)
3-13 psi (21-90 kPa)	36 (160)	89 (396)	214 (952)	54 (240)	50 (5.6)	50 (5.6)	75 (8.5)	75 (8.5)
8-13 psi (55-90 kPa)	36 (160)	89 (396)	214 (952)	144 (640)	50 (5.6)	50 (5.6)	125 (14)	202 (23)

\* With maximum hysteresis of 2.5 psi (17.2 kPa) @ 90° rotation.

**Operation**

The air tubing from a controlling instrument is connected to the actuator's upper housing. With no control pressure to the actuator, the compression spring forces the spring seat and actuator shaft toward the upper housing, but is limited by the E-ring. As the control pressure increases, the spring compression is overcome and the actuator shaft gradually moves outward. Conversely, as control pressure decreases, the spring returns the shaft to the position at which the air pressure on the diaphragm balances the spring tension. For each value of control pressure there is a corresponding position of the shaft.

**Standard Actuator (Figure 1)**



**Figure 1. Standard Actuator.**

**Table 3. Construction Components (Figure 1).**

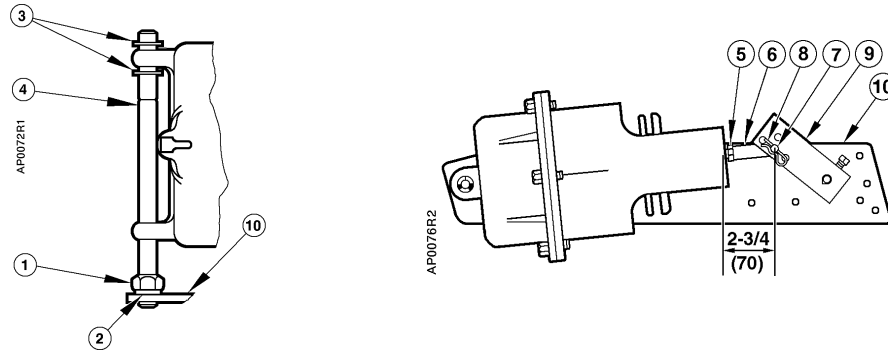
Item	Part No.	Description	Qty.	Material
1	047-061J	Retaining E-ring	1	Steel
2	333-217	1 x 1-1/4 in. Hex Nut	1	Brass
3	—	Spring Retainer	1	—
4	—	Stem Guide Assembly	1	—
5	—	Lower Housing	1	Aluminum
6	333-206 (pkg. of 5)	Diaphragm	1	—
7	599-00413	5/16 in.-18 x 1 Large Hex Cap Screw	6	Steel
8	—	Upper Housing	1	Aluminum
9	—	Helical Compression Spring	1	—
	331-091	3 to 13 psi (21 to 90 kPa)		—
	331-208	3 to 8 psi (21 to 55 kPa)		—
	331-094	8 to 13 psi (55 to 90 kPa)		—
10	—	Piston Plate and Stem Assembly	1	Aluminum /SS
11	—	Retaining C-ring	1	Steel
12	333-197	Stop Kit	—	Steel

**Extended Shaft Mounting—Pivot Actuator**

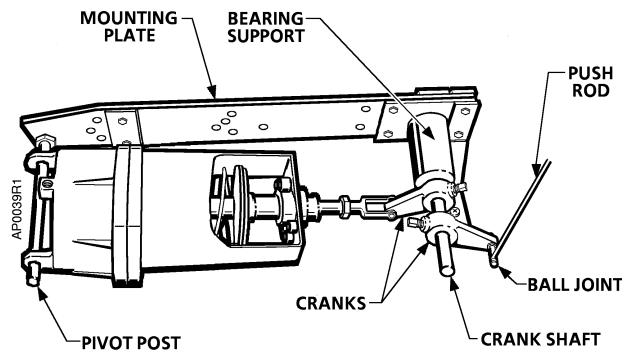
- Order one of the following and see Table 4 for parts lists:  
 Actuator: 331-3011, 331,-3012, 331-3013, or 332-3011
- Slip the 3/4-inch (19-mm) diameter hole in the mounting plate over the damper shaft.
- Slip the crank over the damper shaft (Figure 2). With the actuator assembly to the *left* of the damper shaft, an increase in actuator pressure rotates the damper blade CW when the crank is above the damper shaft (Figure 2), or CCW when the crank is below the damper shaft.  
 With the actuator assembly to the *right* of the damper shaft, an increase in actuator pressure rotates the damper blade CCW when the crank is above the damper shaft or CW when the crank is below the damper shaft.
- Position the mounting plate and attach it to the duct with four screws.
- When the actuator cannot be directly mounted, drive the extended damper shaft using the Remote Mounting Kit 331-618 and Actuator 331-2856 (Figure 3).

**Table 4. Extended Shaft/Frame Mounting Assemblies (Figure 2).**

Item	Part No.	Description	Qty.	Material
1	041-162J	Nut	1	Steel
2	046-020K	Lockwasher	1	Steel
3	047-061K	Retaining E-ring	2	Steel
4	331-565	Pivot Post	1	Steel
5	041-142	Nut	1	Steel
6	333-207	Clevis	1	Zinc Plated Steel
7	331-293	Clevis Pin	1	Zinc Plated Steel
8	331-807	Hitch Pin	1	Zinc Plated Steel
9	331-941	Crank Assembly	1	—
10	331-623	Actuator Mounting Plate	1	Steel
—	034-283	Mounting Screws	4	Steel



**Figure 2. Extended Shaft/Frame Mounting Actuator Assembly.**



**Figure 3. Remote Mounting Kit 331-618 with 331-2856 Actuator Mounted.**

**Frame Mounting - Type A**

Order one each of the following. See Table 4 for parts lists:

Actuator and Clevis: 331-2856, 331-2857, or 331-2858

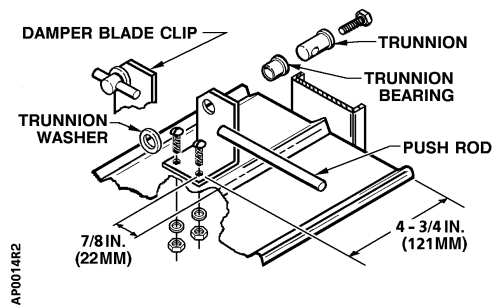
Frame Mounting Kit: 331-833 for one-section damper, 331-834 for two-section damper, or 331-835 for three-section damper

Damper Blade Clip Kit: 331-838 (one per damper section)

All frame mounting kits and the damper blade clip kit must be ordered from the Arrow United or Pacific Air Products.

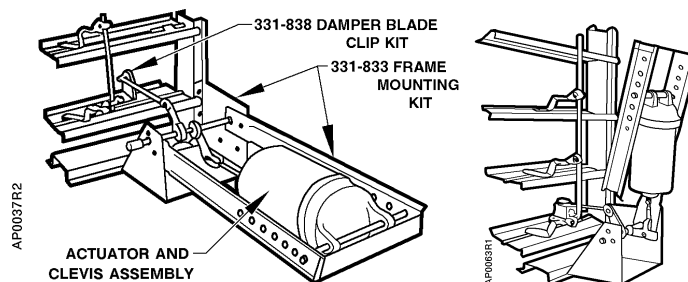
**One-Section Damper  
Kits 331-833 and  
331-838  
(Figures 4 and 5)**

1. Attach the damper mounting bracket to the lower right-hand corner (or upper left-hand corner if necessary) of the damper section with the six screws provided. For Arrow 1770 dampers, add the shim provided between the bracket and bottom of the frame. Have the damper manufacturer drill the holes in the damper frame (Figure 5).
2. Have the damper manufacturer drill the holes in the damper blade for the blade clips (Figure 4). Use the same clip location for both normally open and normally closed dampers. Attach the damper blade clip to the damper blade (Figure 4). Put the damper in its normal position, open or closed. Connect the push rod to the trunnion in the blade clip and tighten the setscrew. Connect the other end of the push rod to the crank on the drive shaft and tighten the trunnion setscrew on the push rod. Position the crank so the push rod is parallel to the bracket, then tighten the crank setscrews.
3. Install the actuator in the actuator support bracket using the pivot shaft and hitch pins. The pivot shaft should be in the holes about 17-1/2 inch (445 mm) from the drive shaft. The actuator support bracket can also mount in the vertical position for installations where space is limited.



**Figure 4. Damper Blade Clip Kit 331-838.**

4. Position the crank driven by the actuator as follows:
  - a. Normally open damper: the crank is above the drive shaft.
  - b. Normally closed damper: the crank is below the drive shaft.
5. Connect the actuator clevis to the crank. Put the damper in its normal position, open or closed. Stroke the actuator 1/4-inch (6 mm) with a hand pump, then tighten the crank setscrews. This will ensure tight damper closure.

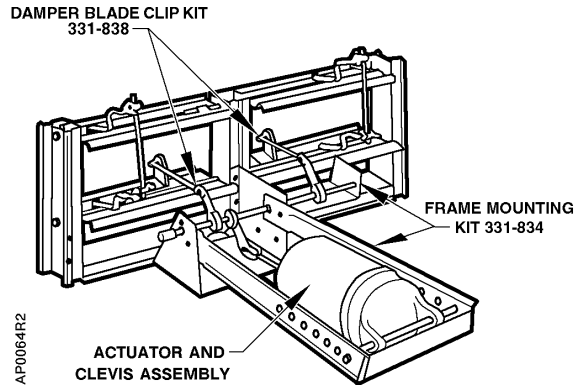


**Figure 5. One-Section Damper.**

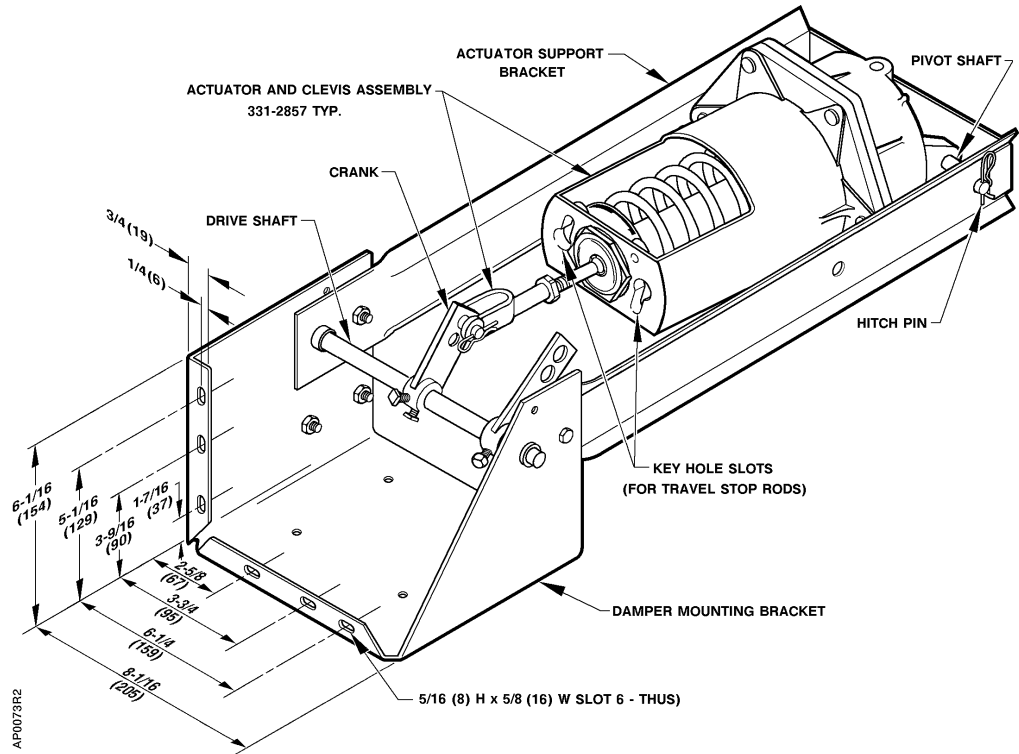
**Frame Mounting -  
 Type A,  
 Continued**

**Two-Section Damper  
 Kits 331-834 and  
 331-838  
 (Figures 6 and 7)**

1. Follow the steps in *One-Section Damper*.
2. Attach the Damper Blade Clip Kit 331-838 to the damper blade in the second damper section. Repeat Step 2 in *One-Section Damper*. The push rod will connect to the extra crank on the drive shaft.



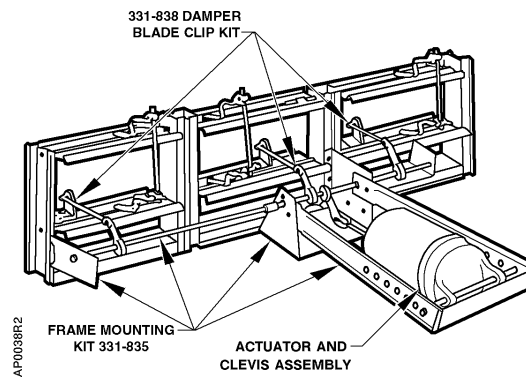
**Figure 6. Two-Section Damper.**



**Figure 7. Actuator and Clevis Assembly 331-2857 (Typical)  
 Attached to Frame Mounting Kit 331-833.  
 Dimensions in Inches (Millimeters).**

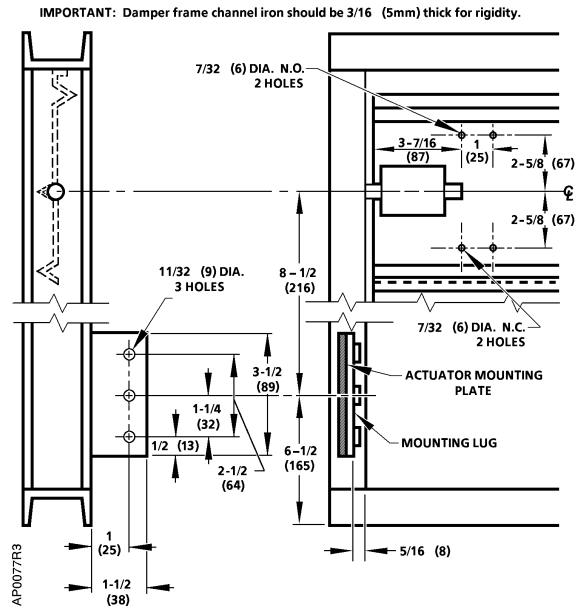
**Three-Section Damper  
Kits 331-835 and  
331-838  
(Figure 8)**

1. Follow Steps 1 and 2 in *Two-Section Damper*.
2. Slide the mini jackshaft through the jackshaft brackets and crank for the third damper section. Use the coupler to attach the jackshaft to the drive shaft. The mini jackshaft and drive shaft should be in a straight line when attaching the jackshaft brackets to the damper frame.
3. Attach the Damper Blade Clip Kit 331-838 to the damper blade in the third damper section. Repeat Step 2 in *One-Section Damper*. The push rod will connect to the crank on the mini jackshaft.
4. Ensure the damper blades in all three damper sections close tightly at the same time. Slight linkage adjustments may be required.

**Figure 8. Three-Section Damper.**

**Frame Mounting -  
 Type B**  
 (Figures 9 through 11)

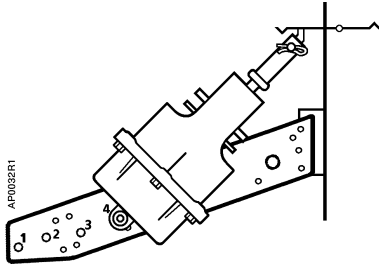
1. Order one each of the following:  
 Actuator assembly: 331-3011, 331-3012, 331-3013, or 332-3011  
 Mounting Lug: 331-569
2. Weld the mounting lug parallel and 5/16-inch (8 mm) from the inside edge of the damper frame and perpendicular to it (Figure 9). Weld the lug along both sides. The lug should be as close as possible to the corner of the damper frame to minimize deflection. The damper manufacturer should weld the lug.



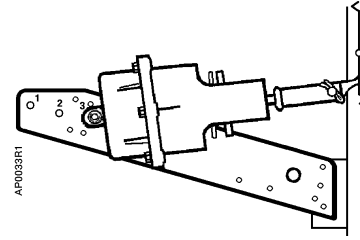
**Figure 9. Frame Mounting—Type B.  
 Dimensions in Inches (Millimeters).**

3. If the damper frame is aluminum, light gauge sheet metal, or an unusual shape, bolt a 3/16-inch (5-mm) thick, flat piece of steel to the frame. Then weld the mounting lug to it.
4. Attach Rocker 333-034 to blade in proper position for normally open or normally closed damper using 2 nuts, 041-230K, and 2 screws, 030-510J, (Figures 10 and 11).
5. Attach the mounting plate to the mounting lug as follows:
  - a. Normally Open damper: attach the plate to the lug (Figure 10). Place the pivot post in Hole 4.
  - b. Normally Closed damper: attach the plate to the lug (Figure 11). Place the pivot post in Hole 3.
6. Fasten the clevis to the rocker. Discard the crank and other parts not used.
7. The actuator mounting plate has a tendency to pivot at the point where the lug is welded to the damper frame when the actuator strokes. It is recommended that some means be devised in the field to prevent this from happening. A threaded rod attached to the mounting plate and duct wall will normally work.

### Frame Mounting - Type B, Continued

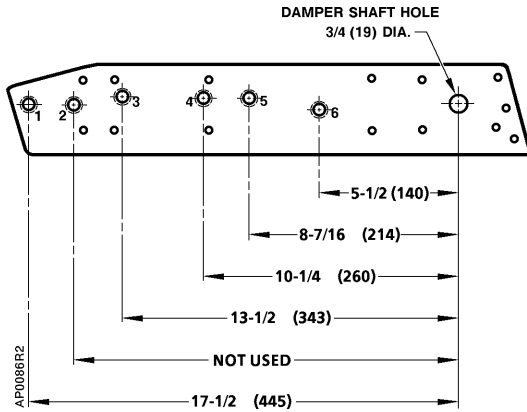


**Figure 10. Frame Mounting, Normally Open Damper.**



**Figure 11. Frame Mounting, Normally Closed Damper.**

### Actuator Mounting

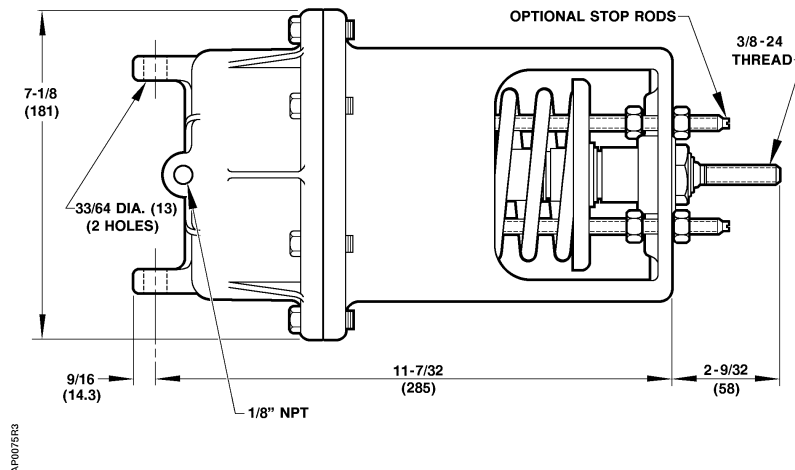


**Figure 12. Actuator Mounting Plate 331-623  
 Pivot Shaft Locations.  
 Dimensions in Inches (Millimeters).**

**Table 5. Mounting Plate Hole Identification.**

Hole	Used For
1	No. 6 Actuator extended shaft mounting.
2	Not used.
3	No. 4 Actuator extended shaft. No. 6 Actuator frame mounting N.C.
4	No. 6 Actuator frame mounting N.O.
5	No. 4 Actuator frame mounting N.C.
6	No. 4 Actuator frame mounting N.O.

### Dimensions



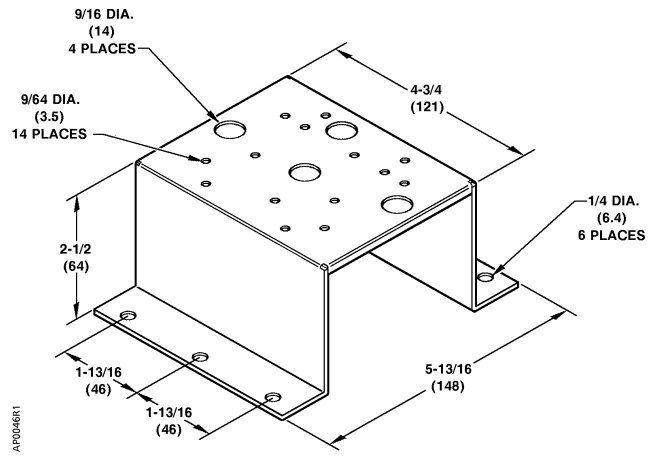
**Figure 13. Extended Shaft Remote Mounting with Travel Stops.  
 Dimensions in Inches (Millimeters).**

**Dimensions,  
 Continued**

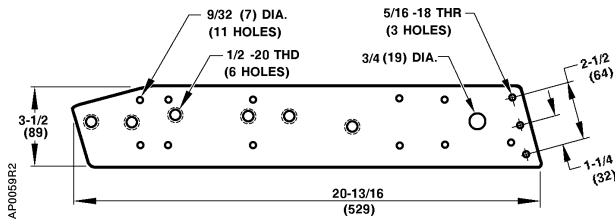
**Offset Mounting  
 Bracket**

This bracket is designed to offset Universal Mounting Plate 331-623 from the duct work.

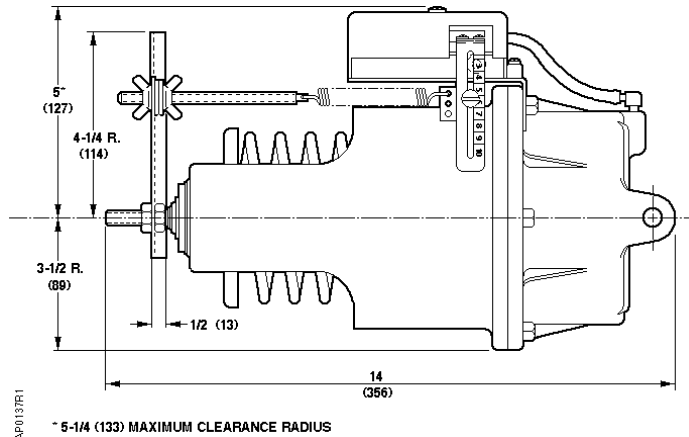
**NOTE:** Depending on the application, two brackets may be required to support the actuator and universal mounting plate.



**Figure 14. Offset Mounting Bracket 333-176.  
 Dimensions in Inches (Millimeters).**



**Figure 15. Actuator Mounting Plate 331-623.  
 Dimensions in Inches (Millimeters).**



**Figure 16. No. 6 Actuator with the  
 RL 147 Positioning Relay Mounting.  
 Dimensions in Inches (Millimeters).**

Information in this publication is based on current specifications. The company reserves the right to make changes in specifications and models as design improvements are introduced. Powers is a trademark of Siemens Building Technologies, Inc. Other product or company names mentioned herein may be the trademarks of their respective owners. © 2001 Siemens Building Technologies, Inc.