

# Extruded Aluminum Louver

**ESV**

"V" Blade • Equipment Screen

## STANDARD CONSTRUCTION

**SUPPORTS:** Shall incorporate rear angle 2" x 2" x 1/4" extruded aluminum to withstand windload of 20 psf, approximately 90 mph wind; spaced on 60" centers

**BLADES:** .081" thick; 6063-T6/T52 extruded aluminum alloy

**BLADE SPACING:** 3"

**FINISH:** Mill

## OPTIONS

Finish - Baked Enamel, Kynar, Anodize  
 Mitered or Post Corner  
 Hinged Access  
 Cap Covers

## NOTES

1. Shipping weight approximately 5 lbs./sq.ft.

## LOUVER SIZE

Panels	Min Panel	Max Single Panel
ESV	12"W x 12"H	60"W x 96"H 40 sq.ft.

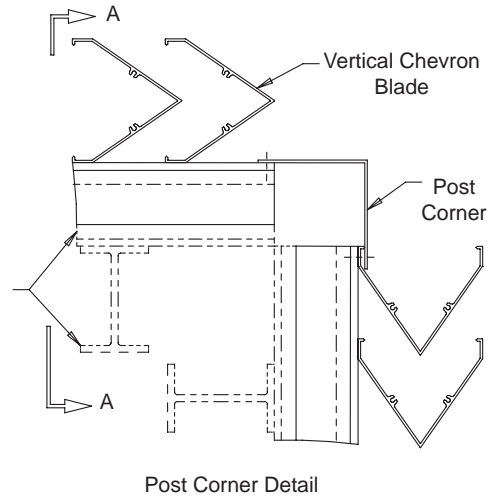
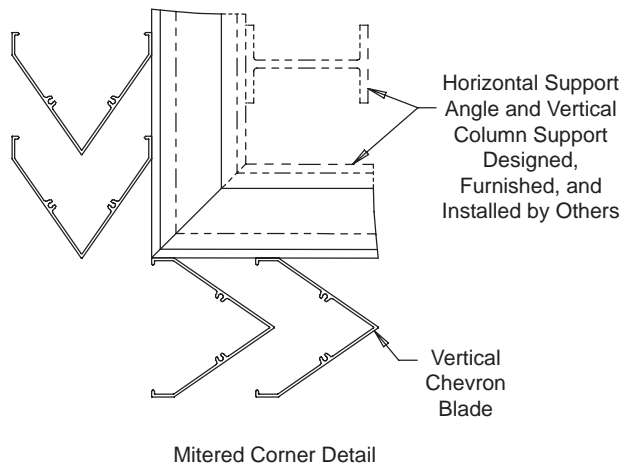
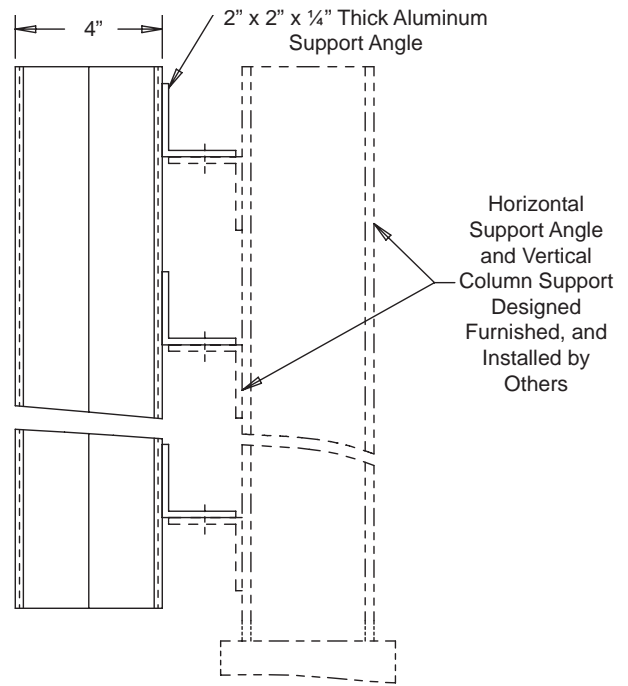

This page intentionally left blank.