

# Extruded Aluminum Louver

**TE15**

1½" Deep • 30° Baffle Blade • Stationary Louver

**STANDARD CONSTRUCTION**

- FRAME:** .063" thick; 6063-T6/T52 extruded aluminum alloy
- BLADES:** .063" thick; 6063-T6/T52 extruded aluminum alloy
- ASSEMBLY:** Mechanically fastened
- SCREEN:** ½" x .051" flattened aluminum birdscreen
- FINISH:** Mill

**OPTIONS**

- Finish - Baked Enamel, Kynar, or Anodize
- Variety of Bird and Insect Screen
- ¾" Usable Flange Frame
- Welded Construction
- Blank-off Panels

**NOTES**

1. "A" width and "B" height are opening dimensions. Louvers are provided approximately ½" undercut.
2. Shipping weight approximately 3.8 lbs./sq.ft.

**LOUVER SIZE**

Panels	Min Panel	Max Single Panel
TE15	12"W x 12"H	60"W x 96"H

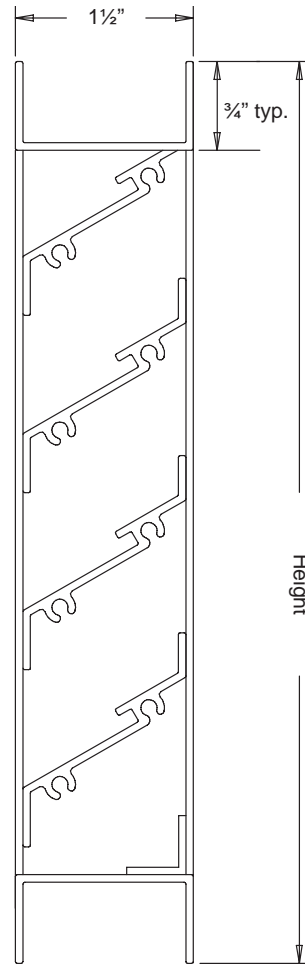

Section View

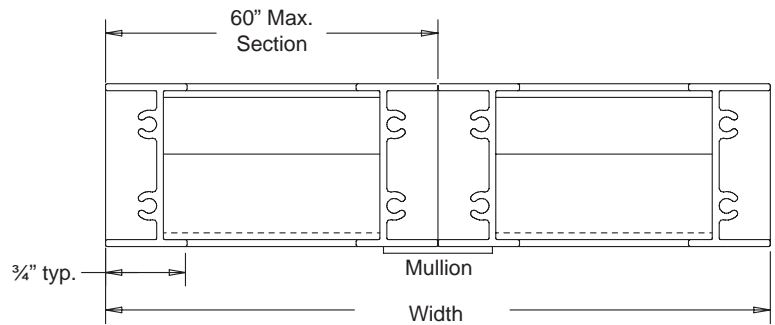
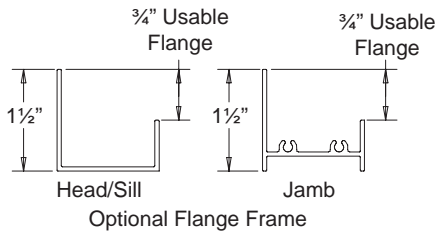

Water Penetration: 400 fpm recommended maximum free area velocity  
 Pressure Drop: 0.10 in.wg at 800 fpm and 5896 scfm  
 Free Area: 7.37 sq.ft. = 46% for 48"W x 48"H test size

Ratings do not include the effect of a birdscreen.

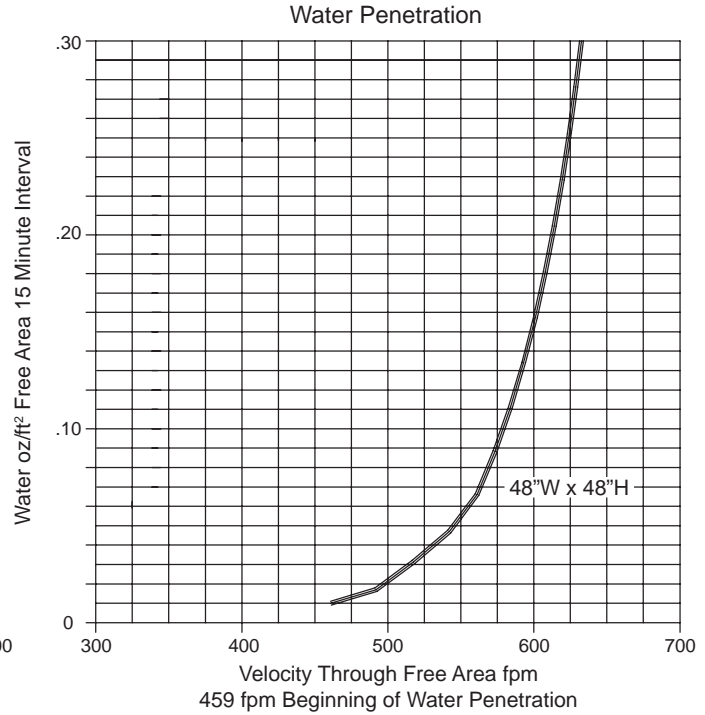
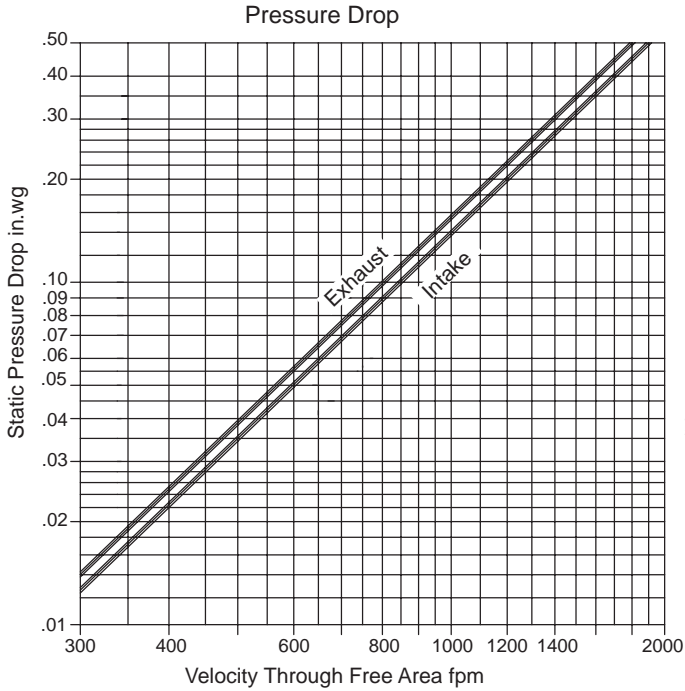

Free Area sq.ft.

		Width								
		12"	18"	24"	30"	36"	42"	48"	54"	60"
Height	12"	0.33	0.52	0.71	0.90	1.09	1.28	1.47	1.66	1.85
	24"	0.78	1.22	1.66	2.11	2.55	2.99	3.44	3.88	4.32
	36"	1.22	1.92	2.61	3.31	4.01	4.70	5.40	6.10	6.80
	48"	1.66	2.61	3.56	4.52	5.47	6.42	7.37	8.32	9.27
	60"	2.11	3.31	4.52	5.72	6.92	8.13	9.33	10.54	11.74
	72"	2.55	4.01	5.47	6.93	8.38	9.84	11.30	12.76	14.22
	84"	3.00	4.71	6.42	8.31	9.84	11.55	13.27	14.98	16.69
	96"	3.44	5.40	7.37	9.34	11.30	13.27	15.23	17.20	19.16