

Formed Steel Louver

SL47A

4" Deep • Straight Blade • Adjustable Louver

STANDARD CONSTRUCTION

- FRAME:** 18-GA galvanized steel
- BLADES:** 18-GA galvanized steel
- ASSEMBLY:** Welded and/or riveted for maximum service
- AXLES:** 1/2" dia. extruded aluminum pin-lock rod with double-sealed bearings
- LINKAGE:** Sealed in one jamb out of the airstream up to 48" wide, concealed in both jambs 48" to 60" in width
- SEALS:** Stainless steel at jambs
- SCREEN:** 1/2" x .051" flattened aluminum birdscreen
- FINISH:** Mill

OPTIONS

- Finish - Baked Enamel, Kynar, or Anodize
- Variety of Bird and Insect Screen (Interior or Exterior)
- Deeper Frames for Blade Rotation Greater than 45°
- Neoprene Blade Edge Seals
- Other Gauges and Materials (Stainless Steel, Copper, Aluminum)
- Flange Frame
- Blank-off Panels

NOTES

1. "A" width and "B" height are opening dimensions. Louvers are provided approximately 1/2" undercut.
2. Shipping weight approximately 11 lbs./sq.ft.

LOUVER SIZE

Panels	Min Panel	Max Single Panel
SL47A	12"W x 12"H	60"W x 96"H

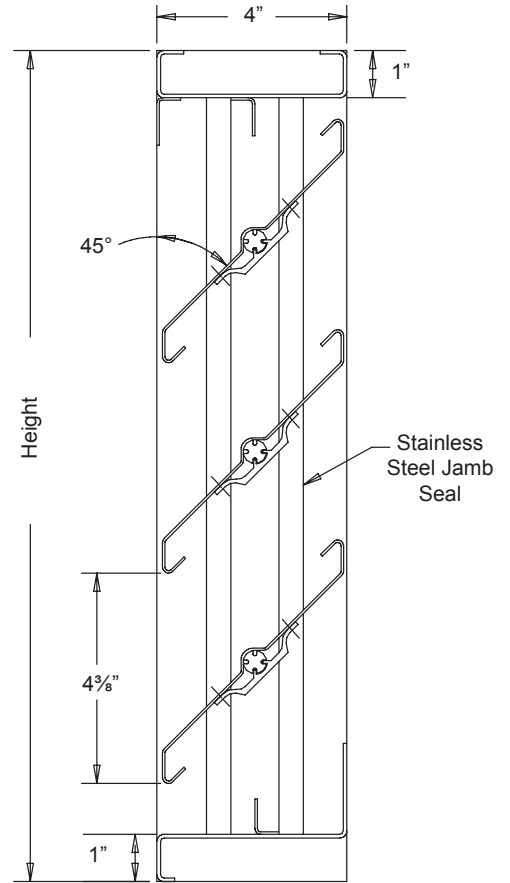

Section View

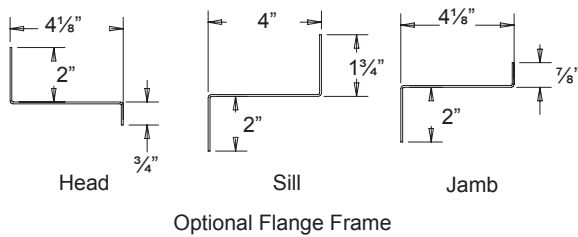

Optional Flange Frame

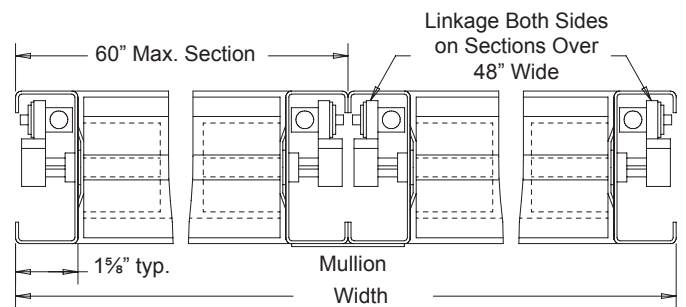

Water Penetration: 600 fpm recommended maximum free area velocity
 Pressure Drop: 0.20 in.wg at 1000 fpm and 4870 scfm
 Free Area: 7.79 sq.ft. = 48.7% for 48"W x 48"H test size

Ratings do not include the effect of birdscreen.

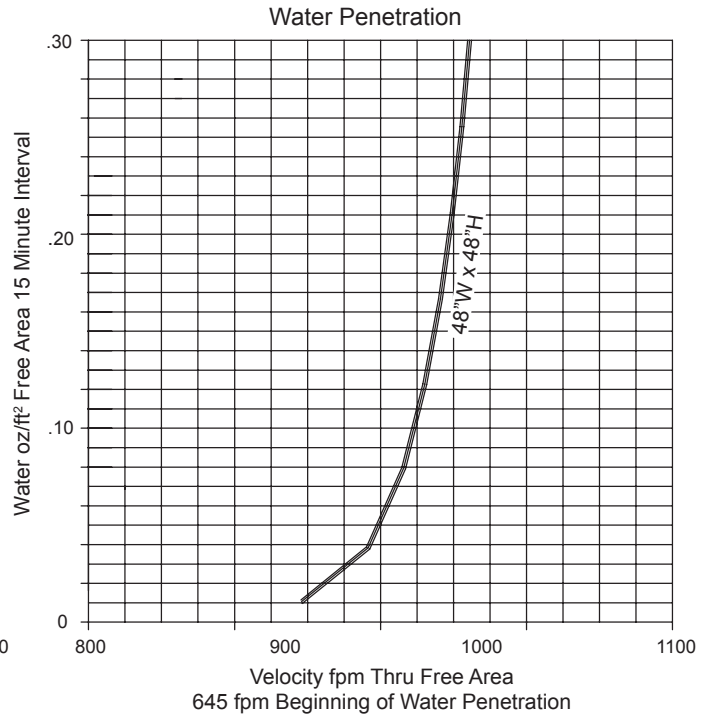
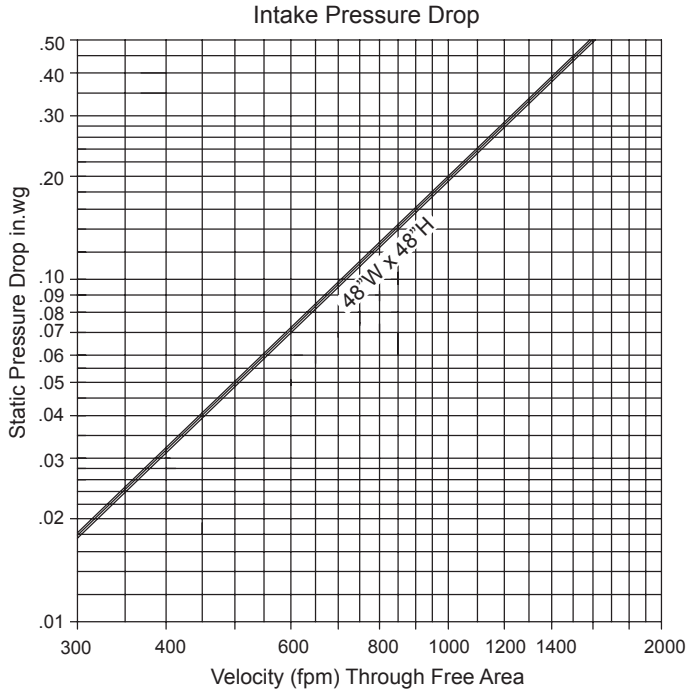

Free Area sq.ft.

		Width								
		12"	18"	24"	30"	36"	42"	48"	54"	60"
Height	12"	0.25	0.39	0.54	0.69	0.84	0.99	1.13	1.28	1.43
	24"	0.72	1.15	1.59	2.02	2.45	2.89	3.32	3.75	4.18
	36"	1.24	1.98	2.72	3.47	4.21	4.95	5.70	6.44	7.18
	48"	1.69	2.71	3.73	4.74	5.76	6.78	7.79	8.81	9.82
	60"	2.13	3.41	4.69	5.97	7.25	8.53	9.81	11.09	12.37
	72"	2.62	4.19	5.76	7.33	8.90	10.47	12.04	13.61	15.18
	84"	3.13	5.01	6.89	8.77	10.65	12.53	14.41	16.29	18.17
	96"	3.58	5.73	7.88	10.02	12.17	14.32	16.47	18.62	20.76