

Formed Steel Louver

SL57

2" Deep • 45° Non-Drainable Blade • Formed Steel Stationary Louver

STANDARD CONSTRUCTION

- FRAME:** 18-GA galvanized steel channel type
- BLADES:** 18-GA galvanized steel
- BLADE SPACING:** 2 1/8"
- ASSEMBLY:** Riveted and/or welded for maximum service
- FINISH:** Mill
- SCREEN:** 1/2" sq. mesh 19-GA galvanized

OPTIONS

- Flange Frame
- Extended Sub-Sills (3" or 5")
- Sub-Frame
- Installation Angles
- Stainless Steel, Copper, Aluminum, Other Steel Gauges
- Finishes - Baked Enamel, Epoxies
- Variety of Bird and Insect Screens
- Blank-Off Panels

NOTES

1. "A" width and "B" height are opening dimensions. Louvers are provided approximately 1/2" undersize.
2. Approximate louver weight is 5 lbs./sq.ft.

LOUVER SIZE

Panels	Minimum Panel	Maximum Panel
SL57	6"W x 5"H	60"W x 96"H

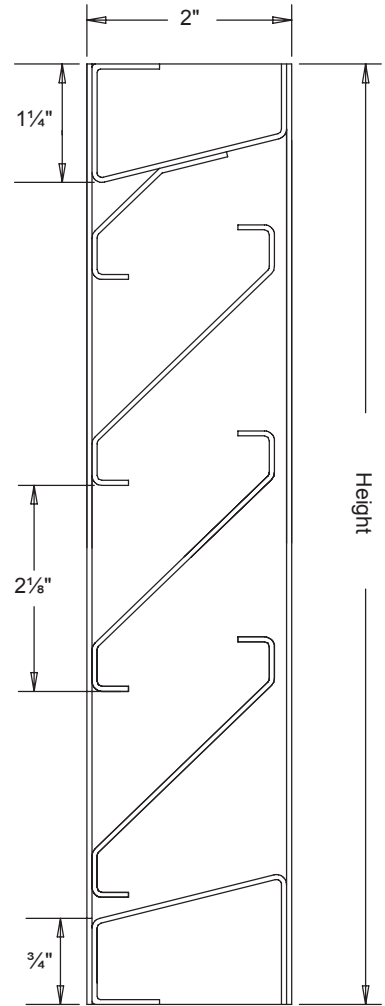

Section View

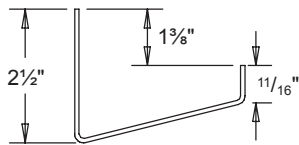

Head

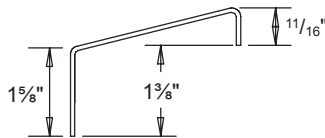

Sill

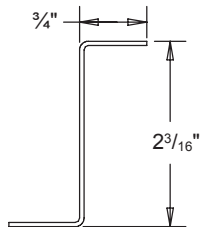

Jamb

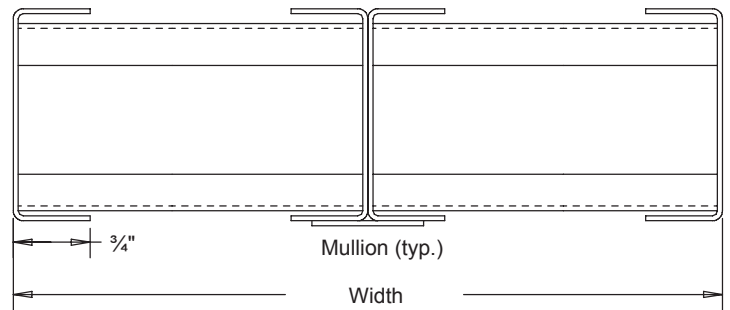

Mullion (typ.)

Width
Top View

This page intentionally left blank.