

# Penthouse

# EP48M/EP63M

4" or 6" Deep • Straight Blade • Mitered Corner • Extruded Aluminum

## STANDARD CONSTRUCTION

- FRAME:** .081" thick nominal; 6063-T6/T52 extruded aluminum alloy with reinforcing rib bosses
- BLADES:** .081" thick nominal; 6063-T6/T52 extruded aluminum alloy with reinforcing rib bosses
- ROOF:** Removable roof .060" thick sheet aluminum reinforced with aluminum bracing where required to take a snow load of 40 lbs/sq.ft. plus a required safety factor
- INSULATION:** ½" thick insulation on underside of roof
- SCREEN:** ½" x .051" flattened galvanized birdscreen
- FINISH:** Mill

## OPTIONS

- Finish - Baked Enamel, Kynar, or Anodize
- Variety of Bird and Insect Screen
- .125" Nominal Construction
- Sloped Roof

## NOTES

1. "A" width and "B" height are opening dimensions. Penthouse dimensions "A" or "B" exceeding 84" shall be shipped in section for field assembly by others.

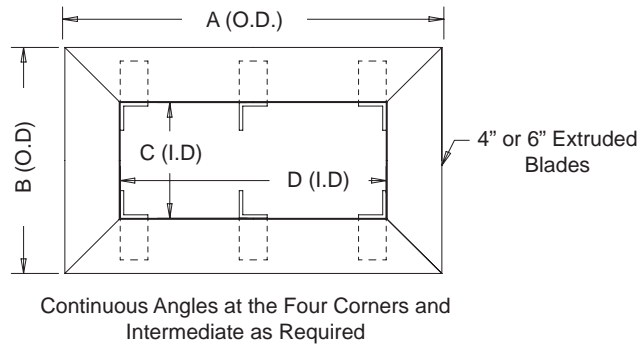
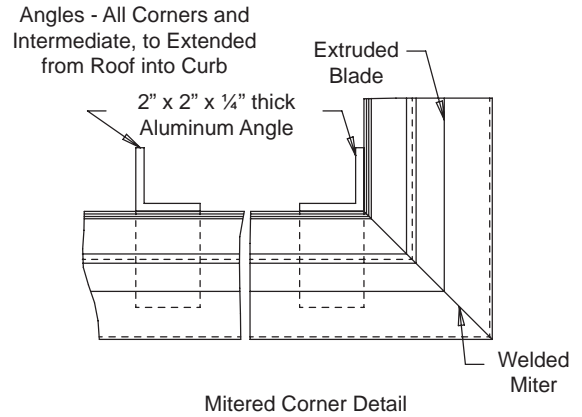
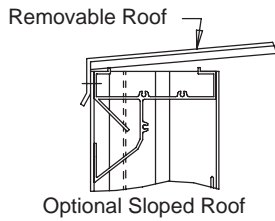
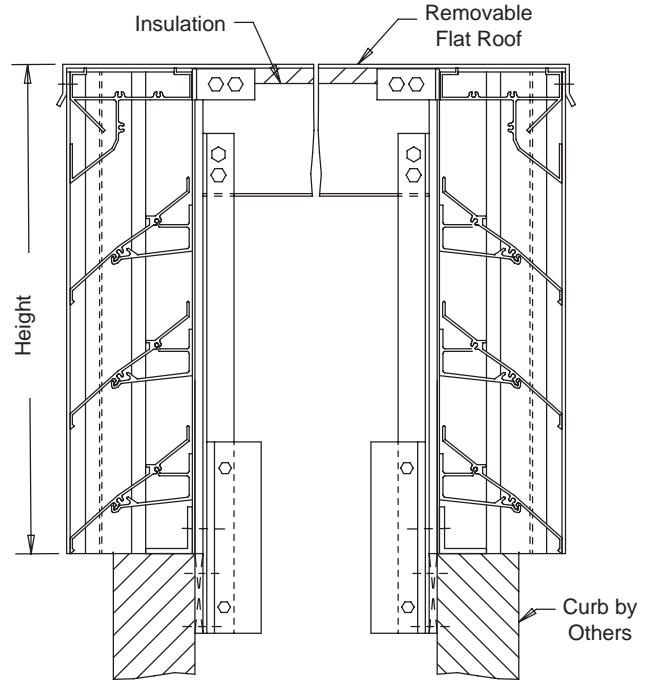

This page intentionally left blank.