

Industrial Damper

GI50

10" Deep • Airfoil Blade • 450°F Max. Temperature • Up to 12 in.wg Static Pressure • Galvanized Steel

STANDARD CONSTRUCTION

- FRAME:** 2" x 10" x 2" - 12-GA galvanized steel formed channel frame
- BLADE:** 16-GA airfoil to max. 48" length; 12-GA airfoil to max. 60" length
- SHAFTS:** 3/4" dia. corrosion resistant, plated cold finished steel
- BEARINGS:** Stainless steel flanged sleeve, bolted to frame
- LINKAGE:** 1/2" dia. inter-connecting rod with trunnion pivot fastener; Located in jamb
- OPERATOR:** Manual hand quadrant or lever arm for electric or pneumatic actuator
- FINISH:** Mill
- TEMP. LIMITS:** 450°F

OPTIONS

- Stainless Steel Blade Edge Seals or Jamb Seals
- Stuffing Boxes and Replaceable Packing
- Variable Flange Sizes
- Finish - Baked Enamel, Kynar, Anodize
- Perimeter Holes - One Flange or Both Flanges
- Other Material

NOTES

1. "A" width and "B" height are opening dimensions. Dampers are provided by inside dimension.

DAMPER SIZE

Panels	Min Panel (ID)	Max Single Panel (ID)
GI50	6"W x 6"H Single Blade 6"W x 12"H Opposed Blades	60"W x 96"H

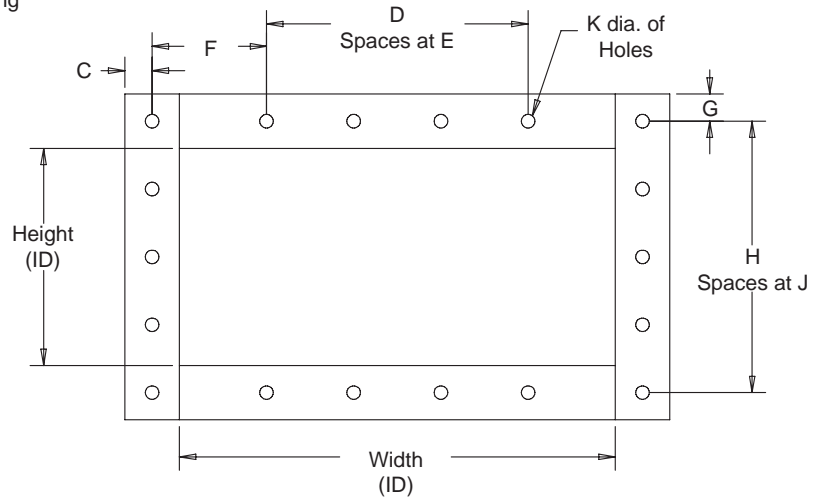
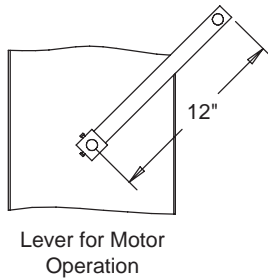
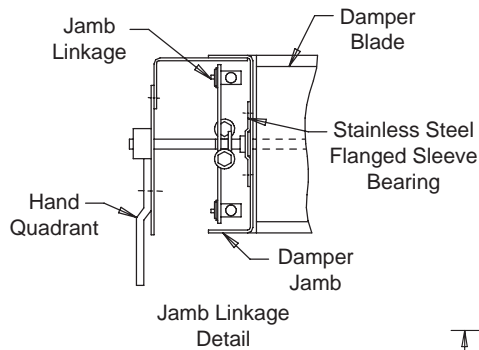
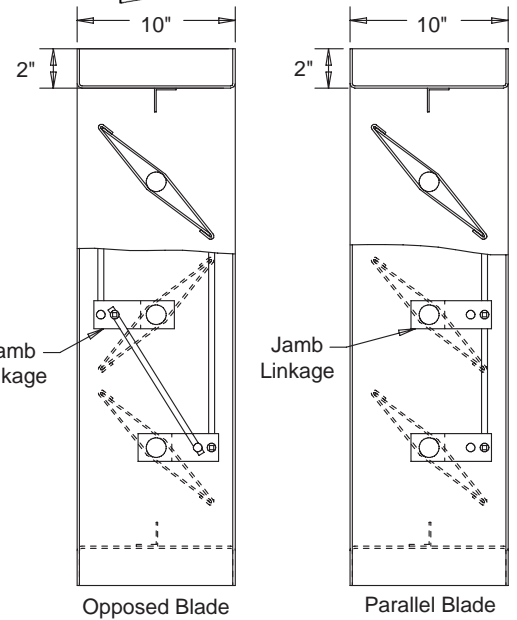
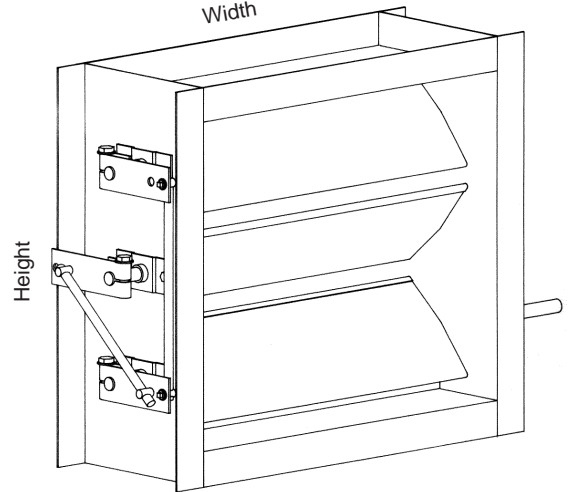

Optional Flange with Holes
(Must Specify Dimensions C-K)

Louvers & Dampers
A Metztek Company

SD-GI50-09.01

P.O. Box 606 • 7435 Industrial Rd • Florence, KY 41042 • Phone (859) 647-2299 • Fax (859) 647-7810

January 2009

Free Area:

10" Deep • Airfoil Blade • 450°F Max. Temperature • Up to 12 in.wg Static Pressure • Galvanized Steel

Pressure drop curves listed are based on AMCA Standard 500, using test set up Fig. 5.3 for damper installed with duct upstream and downstream. Static pressures are corrected to .075 lb/cu.ft air density.

Pressure Drop vs. Duct Velocity
42"W x 42"H (Inside Dimension)
Opposed Blade

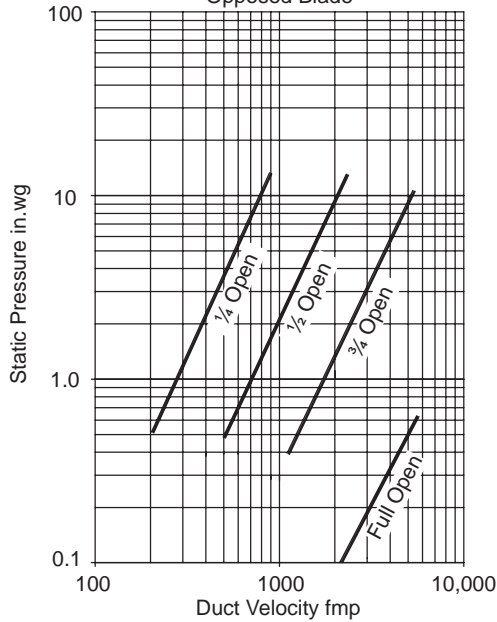

Pressure Drop vs. Duct Velocity
42"W x 42"H (Inside Dimension)
Parallel Blade

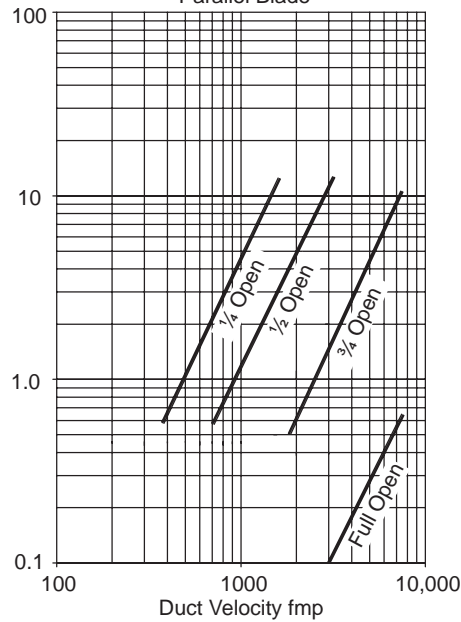

Air Leakage:

Air leakage quantities shown in the chart are results of tests per AMCA Standard 500 and are shown at 1 in.wg differential pressure and corrected to .075 lb/cu.ft. air density.

Air Leakage cfm

		Width								
		12	18	24	30	36	42	48	54	60
Height	12	6	8	11	14	17	19	22	25	28
	24	11	17	22	28	33	39	44	50	55
	36	17	25	33	41	50	58	66	74	83
	48	22	33	44	55	66	77	88	99	110
	60	28	41	55	69	83	96	110	124	138
	72	33	50	66	83	99	116	132	149	165
	84	39	58	77	96	116	135	154	173	193
	96	44	66	88	110	132	154	176	198	220

Air leakage ratings are based on AMCA Standard 500 using test set up 5.4 with a damper closing torque applied to the damper of 38 in.lb/sq.ft. of damper area for a size 60"W x 96"H, with a minimum of 45 in.lb/sq.ft. of damper area for a size 60"W x 8"H.

Damper air leakage shown is based upon publishing only the most conservative leakage results for the L&D Model GI50 Industrial Damper for an entire range of damper sizes.

To ensure proper damper operation and air leakage performance for this damper design. The static pressure/blade length limits shown provide the user with this information and in addition provides a relationship between damper cost and the application.

For determining leakage values greater than 1 in.wg to a maximum of 12 in.wg use the multiplier correction chart below.

Static Pressure	2	3	4	5	6	7	8	9	10	11	12
Multiplier Correction Factor	1.5	2.0	2.3	2.7	3.0	3.3	3.6	3.9	4.3	4.5	5.0

The GI50 damper design at a blade length of 6" has a maximum allowable blade deflection of L/360 for the static pressure indicated on the chart. At reduced blade lengths higher static pressure limits can be attained without sacrificing damper operating and performance characteristics.

